





... the most important reading matter for everyone concerned with environmental engineering in Germany.

The core competence of environmental engineering design at ASSMANN BERATEN + PLANEN lies

- in the development and design of environmental engineering facilities
- in the taking account of environmental requirements in the design of all kinds of projects: residential, commercial and industrial developments, infrastructure projects etc.

Environmental design is integrated into a complete and wide-ranging programme of general total design services.

The individual components of the total design services, which can also be provided separately, are:

- Design of environmental facilities/complete plants
- Submission and management of approval applications
- Project management
- Design team co-ordination
- Cost and time schedule management
- Site supervision
- Acquisition of external specialists as required

During the project development we can not only advise you on the technical design, but also, in conjunction with recognised experts provide advice on:

- Grants and public funding
- Financing
- Operational simulations



**VOLKSWAGEN AG**

Unterlagen zur Anzeige gem. § 67 (2) BImSchG für die Anlage

**Anlage für den Bau von Kraftfahrzeugmotoren**

Nr. 3.24 Sp. 1 des Anhangs zur 4. BImSchV

hier:

**Werk Salzgitter der VOLKSWAGEN AG**



**Volkswagen AG**  
**Anlage für den Bau von Kraftfahrzeugmotoren**

Inhalt

A.	Angaben zur Gesamtanlage	4
1.	Standort und Umgebung	5
1.1	Katasterplan	5
1.2	Werkspan	6
2.	Bestehende Genehmigungen	7
2.1	Gesamtanlage	7
2.2	LAU/HBV-Anlagen	8
3.	Angaben zur Gesamtanlage	10
4.	Gliederung der Gesamtanlage	12
4.1	Gliederungsgrundsätze	12
4.2	Einteilung der Gesamtanlage in Segmente	13
5.	Eingangsmaterialien, Produkte	14
5.1	Stoffeingänge	14
5.2	Stoffausgänge/Produkte	15
5.3	Gefahrstoffkataster	16
6.	Emissionen	22
6.1	Gasförmige und partikelförmige Emissionen	22
6.2	Geruchsemissionen	22
6.3	Lärm	23
7.	Abfälle	23
8.	Abwasser	26



1. Volkswagen AG, Salzgitter, certification of an existing plant in accordance with the Federal Pollution Control Act (BImSchG)
2. Hoheneggelsen, hazardous waste landfill site, housing of transfer ramp

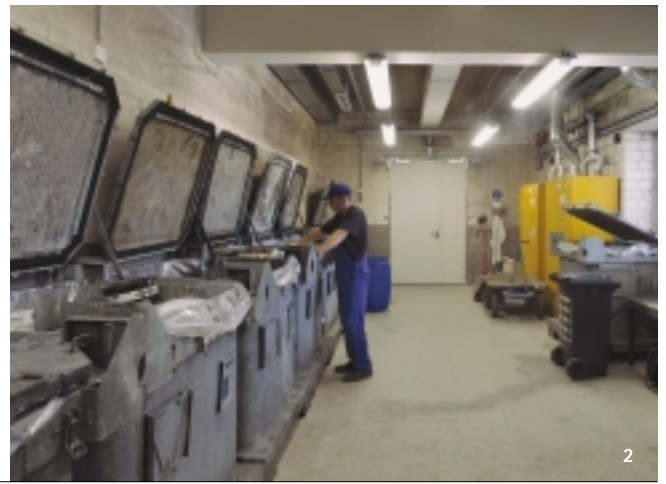

## Environmental Engineering Economics

The successful realisation of a project does not only depend on the handling of the technical aspects, but also on diligent calculation of the investment and operating costs. We have carried out a large number of projects, where the aim was

- to optimise investment costs
- to optimise operating costs
- to optimise life-cycle costs.

Therefore we can offer you a great wealth of experience.

6.1 Standort 1  
6.1.1 Var. 1.1



Investitionskosten (IK)		
Bauwerk, Einrichtung, Element	Fläche [ha]	Kosten brutto [T€]
5.1 Umschlag	0,53	4.134,0
5.4.1EAB	1,00	4.584,0
Innere Erschließung:		
- Verkehrsflächen	0,44	358,0
- Medien	--	968,0
- Sonstiges (Zaun, Außenanlagen)	0,96	337,0
Außere Erschließung:		
- Straße	--	--
- Schiene	1,83	2.048,0
- Medien	--	142,0
Grunderwerb eigen	0,58	15,0
Grunderwerb fremd	4,18	427,0
<b>Summe:</b>	<b>4,76</b>	<b>13.013,0</b>

Jährliche Betriebskosten (LK)		
Bauwerk, Einrichtung, Element	Menge	Kosten brutto [T€]
Umschlag		
- Energie	263.200 kWh	46,4
- Verschlebelok	--	8,2
EAB		
- Strom	257.320 kWh	45,4
- Wärme	12.210 m <sup>2</sup>	--
- Wasser	1.000 m <sup>2</sup>	3,4
Unterhaltung	12.553 T€	62,8
Pacht/Miete	--	--
Bahntransport, Sanierung Bahnstrecke	767 T€	51,1
<b>Summe LK:</b>		<b>217,3</b>

Jahreskosten			
Bauwerk, Einrichtung, Element	IK [T€]	KFAKR	LK [T€]
Investition IK 10	3.368,0	0,11723	394,8
Investition IK 25	9.202,6	0,05743	528,5
Investition IK un	442,3	0,03000	13,3
Betrieb LK			217,3
<b>Summe:</b>			<b>1.153,9</b>



1. Braunschweig, Waste Disposal Centre, interim store for hazardous waste
2. Wolfsburg refuse tip, sorting room of the interim store for hazardous waste
3. City of Braunschweig, study for solid waste transfer station, cost comparison calculation
4. TAD Joint Board, Ulm, Ulm Donautal, waste-fuelled power station, cost and quality controlling

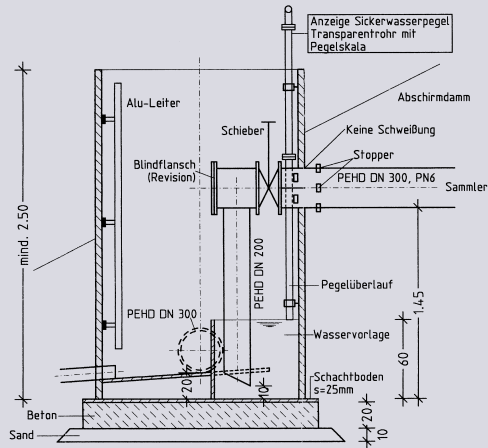

1. MABEG Entsorgungengineering mbH & Co. KG, Spain, filter dust repository, seepage water shaft

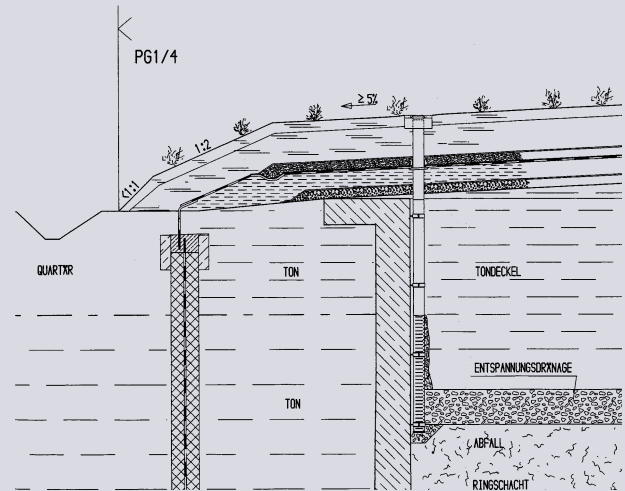

2. Hoheneggelsen, hazardous waste landfill site, surface sealing

## Environmental Engineering Detailed solutions



We nurture a regular exchange of ideas and experience with the Technical University (TU) Braunschweig. The TU Braunschweig is able to integrate our practical experience in the form of seminars which we provide into its programme of lectures.

ASSMANN BERATEN + PLANEN can call upon the results of research and development work performed at the various institutes within the Technical University. Therefore the "best available techniques" (BREF) according to the IPPC Directive 96/61/EC will be implemented.

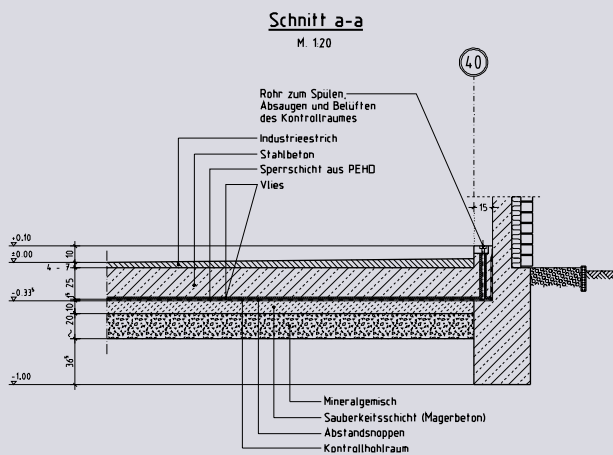

3. Volkswagen AG, Braunschweig, floor sealing system for manufacturing waste transfer hall

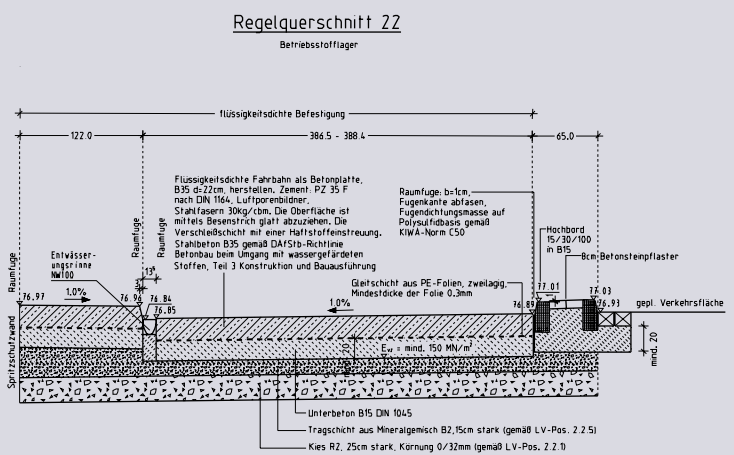

4. Volkswagen AG, Poznan/Poland, lubricants store, impermeable concrete floor slab

Braunschweig +49 531 3901-0  
Berlin +49 30 399903-0  
Delmenhorst +49 4221 916785

Dortmund +49 231 725480-0  
Dresden +49 351 466630-0  
Hamburg +49 40 514971-0

Hannover +49 511 27900570  
Jena +49 3641 5372-0  
Magdeburg +49 391 73539-0

München +49 89 680091-0  
Potsdam +49 331 887152-0  
Wolfsburg +49 5363 97688-0

Budapest +36 1 4400-106  
Moskau +7 095 93758-25  
Poznań +48 61 8473054